

Mini Pumps - Technical Summary

Mini pumps are not designed to run dry. They are water cooled and lubricated by the condensate flowing through them. They require a float switch to detect the presence of water in the drain pan and activate the pump only when the water is present.

Mini pumps always consist of two elements:

1. Pump body - includes an electronic PCB and the pump motor.
2. Reservoir - contains the filter and the switching mechanism to activate the pump. This must always be kept level and clean for proper operation of the float switch. The filter must be cleaned regularly.

Mini Pump Styles:

1. Split type - (Orange and Aqua series) are designed with separate pump and reservoir.
2. Mono bloc type - (Lime or Blanc series) are designed with both the pump and reservoir as one integral unit sharing a common body.

Mini pumps have two cable connections:

1. Power supply cable - colour coded for different voltages. Conductors for 115 volt pumps are white, black and green. Conductors for 230 volt pumps are red, black and green. (24V models have grey wires)
2. Overflow switch cable - designed to break the communication wire between the condenser and the evaporator in case the water level in the reservoir rises to an unacceptable level. This cable has 3 conductors: grey (common), purple (normally closed) and orange (normally open). This colour coding is identical for all pump models except the mini Blanc which has grey and purple only. During overflow condition, the pump will continue to operate. Connection of the overflow switch is imperative for safe operation.

Correct pump wiring:

Mini and Maxi models are available in several voltages. Power supply to the pump should always be connected to the incoming power terminal block on the evaporator (not a separate circuit) to ensure that the pump is powered whenever the evaporator is powered. Some building codes may require a separate circuit for a pump which will override our power wiring instructions. Building codes may also require a disconnect switch for the evaporator. The pump must be connected to the load terminals to isolate both the pump and evaporator.

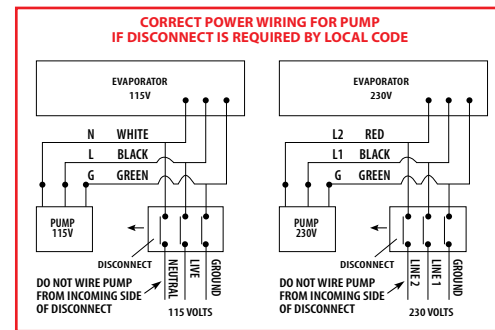

Why a breather tube is required:

When the pump begins sucking water out of the reservoir, an air lock will be created - unless an air intake opening is provided on top of the reservoir. The reservoir relies on gravity, so it must always be below the drain pan.

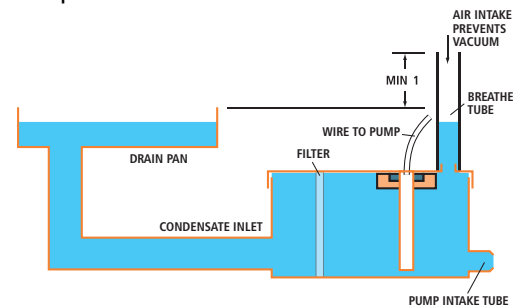

Effect of a dirty filter:

If the filter is clogged, the condensate cannot pass through to raise the float. If the float does not rise, the magnet will not activate the pump and the condensate will back up until it overflows the drain pan.

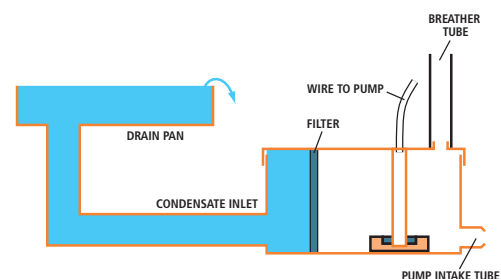

Operating Sequence of a Mini Pump

1. Pump is in Standby Mode:

Pump is off, float rests on bottom of reservoir, overflow switch status is normal so contacts across grey and purple wires are closed and communication wire from condenser to evaporator remains energized.

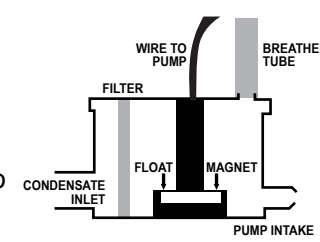

2. Pump Enters Operation Mode:

The evaporator condenses water which flows into the drain pan and through the drain hose into the reservoir lifting the float 3/4" activating the pump. The pump empties the reservoir, lowering the float, causing the pump to switch off. (A small amount of water will remain in the reservoir) The pump returns to standby mode. Overflow switch status is normal, wires are closed and communication wire from condenser to evaporator remains energized. Cycle repeats indefinitely as long as water level remains within normal limits.

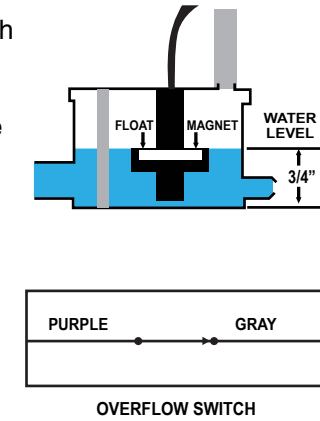

3. Pump Enters Alarm Mode:

The pump enters operation mode. Water level continues to rise due to pump failure, blockage or an undersized pump. The water level reaches 15/16". The overflow switch activates changing the status to abnormal. The pump continues to run but contacts across the grey and purple wire open, breaking the communication circuit to the evaporator, preventing it from producing any more condensate, and shutting down the system. When occupant notices AC is not running they will contact a service technician to investigate and service.

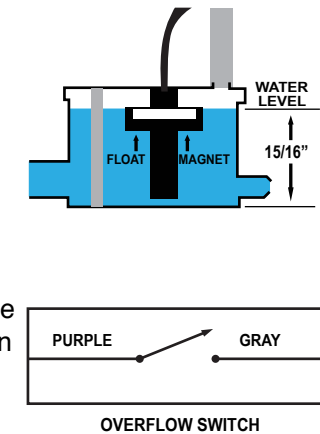

4. Pump reverts to standby mode:

Once the reason for the high water level has been diagnosed and corrected, the pump reverts to standby mode.

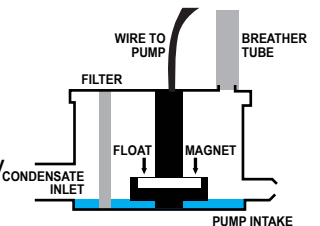

Note: The reservoir must always be set level to permit proper movement of magnetic float.

Peristaltic Pumps - Technical Summary

Three Major benefits of a peristaltic pumps:

1. The ability to run wet or dry enables intermittent operation with a reservoir and float switch, or continuous with the evaporator.
2. The capability to pump contaminated water from an evaporator coil during condensate production.
3. High level of suction enables remote mounting up to 40 feet away from the evaporator.

Peristaltic pump design:

Peristaltic pumps operate using a rotor wheel which is electrically turned at a slow speed and has two or more roller wheels spaced at points along its perimeter. These rollers compress a rubber tube, pinching it closed at each roller location. As the rotor turns, fluid inside the tubing is forced to flow in the same direction as the rotor. Before the pinch point is released, another roller pinches the starting point, preventing any back flow of liquid. This 'peristaltic' action produces a high level of suction, but has a limited volume.

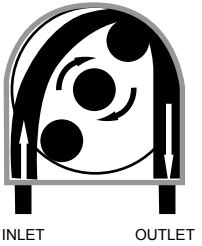

Peristaltic Styles:

Mechanical - uses a float inside a reservoir which is mounted below the drain pan within the evaporator enclosure. Like a mini pumps, the reservoir requires a breather tube to prevent air lock. The pump assembly can be remotely mounted up to 10 feet away and is connected to the reservoir with 1/4" id tubing as well as a communication cable. Condensate water entering the reservoir raises the float, sending a signal which starts the pump. The mechanical type peristaltic pump includes the added benefit of an overflow switch similar to the mini pumps, however, the pump comes with a 3 pin plug and the cable to connect the overflow switch to the evaporator must be field supplied.

Universal - For installations where a reservoir is not practical or distant remote mounting is required. This pump incorporates a twin lead sensor cable with 2 tips, 1 red and 1 blue, each of which are clipped onto a refrigeration component such as the hot liquid line and the cold gas line of the refrigeration circuit. When a preset temperature differential is detected between the 2 tips, the pump begins to operate and removes any condensate as it is produced. When the temperature differential subsides the pump switches off. This pump does not incorporate an overflow switch for the evaporator.

MECHANICAL

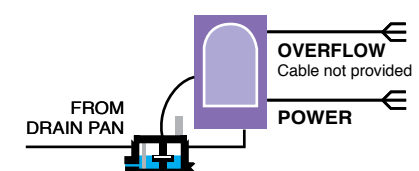

UNIVERSAL

